

SEZIONE B-B

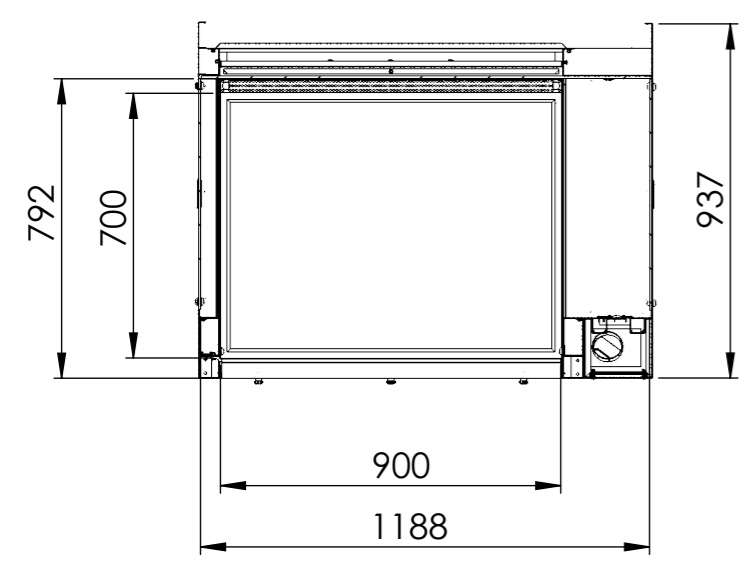

SEZIONE A-A

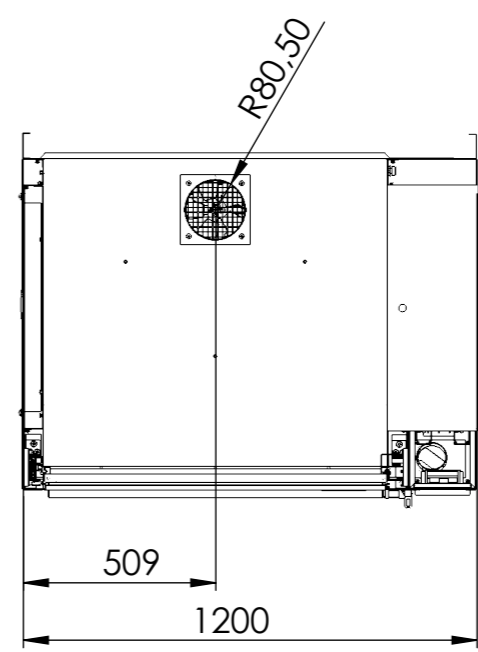

Dim. lineari: da 0 a 1000 Tolleranze: ± 0,5	TOGLIERE BAVE E SPIGOLI VIVI	Quantità 1	Materiale: Vedi Distinta Base
Dim. lineari: oltre 1000 Tolleranze: ± 1	Sviluppo —	Peso Kg 390.39	Finitura: VERNICIATO
Toll. ang.: > ± 0,5°	Denominazione: ASSIEME GENERALE		
PREPARATO FC	DATA 15/05/18	Macchina tipo: CHEMFAST PREMIUM 12 SP	
VERIFICATO FC	DATA 15/05/18	CODICE DISEGNO: K6 01700 D02	
Riproduzione vietata			
MOD. 37.64 REV.03 DATA 18/07/2008		SCALA 1:20	REV. DEL: 00 15/05/18